

GA1A1S201WP

Surface-mount Package OPIC™ Logarithmic Output Ambient Light Sensor



■ Description

The GA1A1S201WP is an surface-mount ambient light sensor with a spectral response similar to that of the human eye. This response curve means the sensor is highly accurate when used as the basis of an ambient light sensor, or camera exposure sensor.

The integrated photodiode and amplifier circuit makes the GA1A1S201WP ideal for use in space-constrained applications, or for anywhere a sensor may be wanted but wasted space is not.

■ Features

1. Logarithmic output, suitable for both indoor and outdoor illumination
2. Light sensitivity similar to the human eye's response curve
3. OPIC light detector: Integrated photodiode and amplifier circuit
4. Compact package (1.6 mm × 2.0 mm)
5. Stable over specified temperature range
6. Lead-free and RoHS-directive compliant

■ Agency Approvals

1. Compliant with RoHS directive (2002/95/EC)
2. Content information about the six substances specified in "Management Methods for Control of Pollution Caused by Electronic Information Products Regulation" (popular name: China RoHS) (Chinese: 电子信息产品污染控制管理办法); refer to page 5.

■ Applications

1. Mobile Phones
2. TV/Monitors
3. Cameras

OPIC is a trademark of Sharp Corporation.

Notice The content of data sheet is subject to change without prior notice.
In the absence of confirmation by device specification sheets, SHARP takes no responsibility for any defects that may occur in equipment using any SHARP devices shown in catalogs, data books, etc. Contact SHARP in order to obtain the latest device specification sheets before using any SHARP device.

External Dimensions

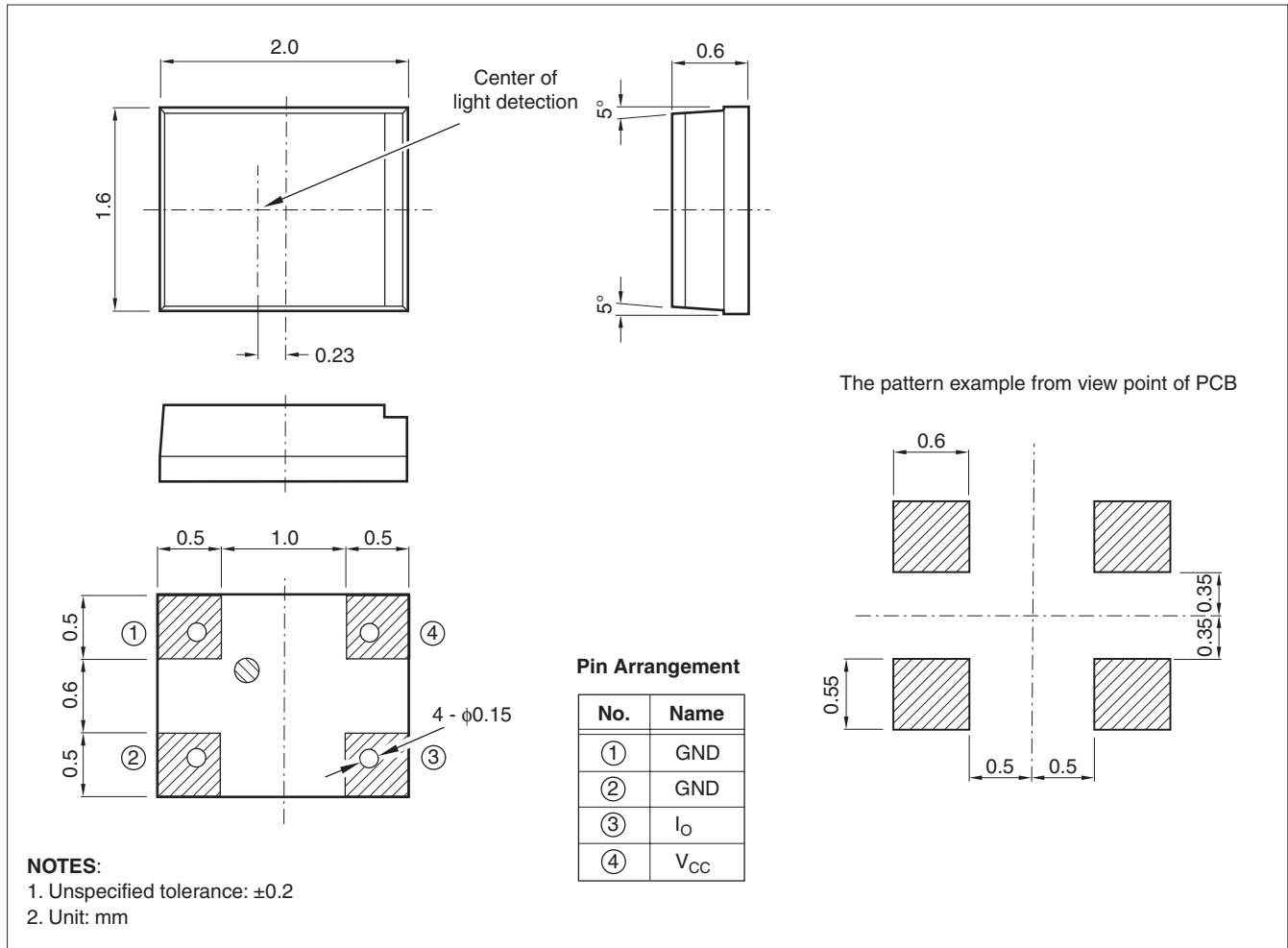

Block Diagram

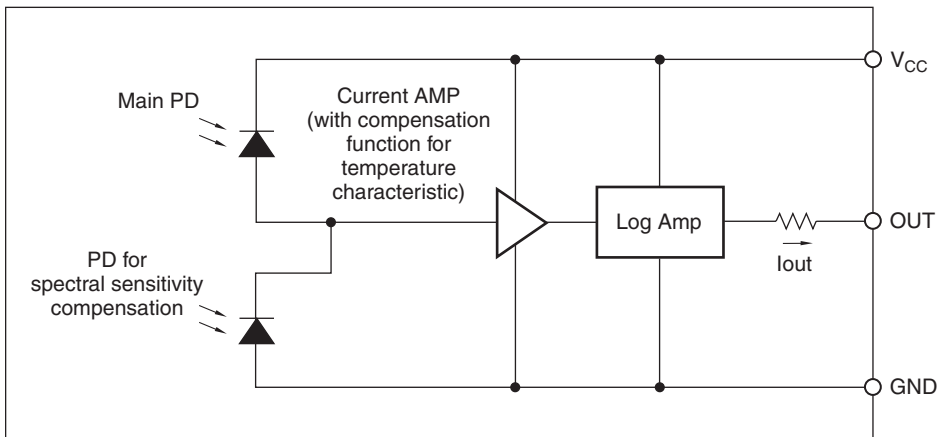

■ Absolute Maximum Ratings

(Ta = 25°C)

Parameter	Symbol	Rating	Unit
Supply voltage	V _{CC}	-0.3 to +7.0	V
Output current	I _O	1	mA
Operating temperature	T _{opr}	-40 to +85	°C
Storage temperature	T _{stg}	-40 to +85	°C
Soldering temperature*	T _{sol}	250	°C

*Within 10 s and no more than twice. See the Temperature profile on Page 4.

■ Recommended Operating Conditions

(Ta = 0°C to 70°C)

Parameter	Symbol	Min.	Max.	Unit
Operating supply voltage	V _{CC}	2.3	3.2	V
Illuminance range	E _V	3	55000	lx

■ Electro-optical Characteristics

(Ta = 25°C, V_{CC} = 2.9 V)

Parameter	Symbol	Condition	Min.	Typ.	Max.	Unit
Supply current *2	I _{CC}	E _V = 1000 lx	40	70	150	μA
Output current *1, *2	I _{O1}	E _V = 100 lx	16	20	24	μA
	I _{O2}	E _V = 1000 lx	27	30	33	μA
	I _{O3}	E _V = 0 lx	—	—	1	μA
Output current Temperature coefficient	α1	-30°C to +70°C E _V = 1000 lx	—	—	0.25	%/°C
	α2	-0°C to +50°C E _V = 1000 lx	—	—	0.2	%/°C
Peak sensitivity	λ _p		—	555	—	nm
Rise time (10% to 90%)*3	tr1	E _V = 100 to 55000 lx, R = 27 kΩ	—	—	150	μs
	tr2	E _V = 3 to 55000 lx, R = 27 kΩ	—	—	5	ms
Fall time (10% to 90%)*3	tf1	E _V = 100 to 55000 lx, R = 27 kΩ	—	—	150	μs
	tf2	E _V = 3 to 55000 lx, R = 27 kΩ	—	—	15	ms
Output current difference	ΔI	I _O (incandescent lamp E _V = 100 lx) -I _O (fluorescent lamp E _V = 100 lx) *4	-2	—	2	μA

*1 Sensor output vs. illuminance is logarithmic. I_O = 10 × log(E_V) in μA.*2 E_V = Illuminance by CIE standard light source A (tungsten lamp).

*3 Illuminance is white LED.

*4 White LED is used on mass production line for inspections instead of fluorescent lamp.

■ Output Current Characteristics (TYP.)

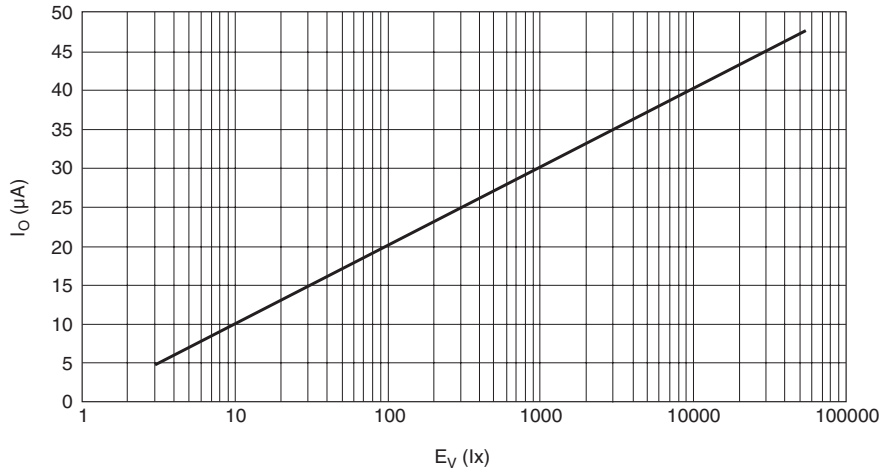

■ Manufacturing Guidelines

● Storage and Handling

1. Store these parts between 5°C and 30°C, at a relative humidity of less than 70%.
2. After breaking the package seal, maintain the environment within 5°C to 25°C, at a relative humidity of less than 60%, and mount the parts within three days.
3. When storing the parts after breaking the seal, Sharp recommends storage of no longer than two weeks in a dry box or by resealing the parts in a moisture-proof bag with a desiccant.
4. Do not bake these parts unless the humidity indicator within the package changes color or if the handling guidelines given above could not be followed. Bake these parts only once, and while the parts are still in tape-and-reel. Suspend the reels by the spindle in the oven, instead of laying the reels flat. Bake the reels at 65°C for 48 hours. Less preferable is to bake the parts either temporarily mounted or on a metal tray at 125°C, for 16 to 24 hours.

● Soldering Information

1. When using solder reflow methods, follow the time and temperature profile shown in Figure 1. Sharp recommends sending parts through this process two times or less.
2. If using an infrared lamp to preheat the parts, such heat sources may cause localized high temperatures in the part's resin. Be sure to keep the heat profile within the guidelines shown.
3. Do not subject the package to excessive mechanical force during soldering as it may cause deformation or defects in plated connections. Internal connections may be severed due to mechanical force placed on the package due to the PCB flexing during the soldering process.
4. Sharp recommends checking the soldering process to ensure these guidelines are followed.

Fig. 1 Soldering Temperature Profile

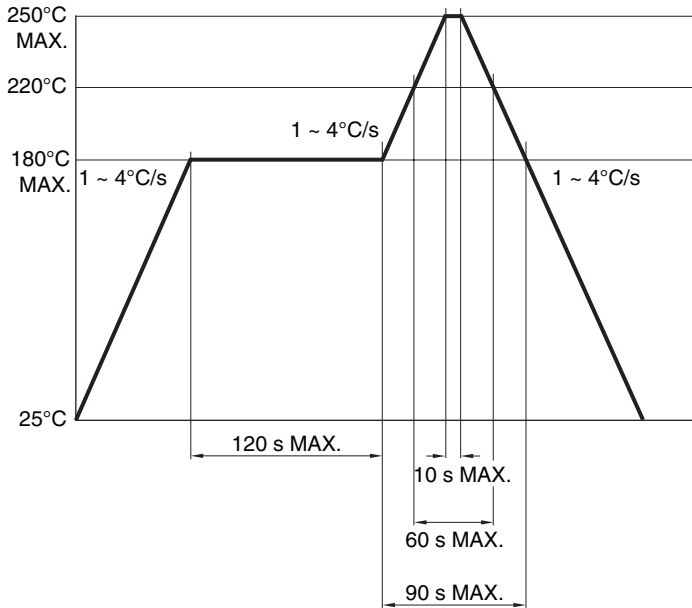

● Cleaning Instructions

1. Confirm this device's resistance to process chemicals before use, as certain process chemicals may affect the optical characteristics.
2. Solvent cleaning: Solvent temperature should be 45°C or below. Immersion time should be 3 minutes or less.
3. Ultrasonic cleaning: The effect upon devices varies due to cleaning bath size, ultrasonic power output, cleaning time, PCB size and device mounting circumstances. Sharp recommends testing using actual production conditions to confirm the harmlessness of the ultrasonic cleaning methods.
4. Recommended solvent materials: Ethyl alcohol, Methyl alcohol, and Isopropyl alcohol.

■ Presence of ODCs (RoHS Compliance)

This product shall not contain the following materials, and they are not used in the production process for this product:

- Regulated substances: CFCs, Halon, Carbon tetrachloride, 1,1,1-Trichloroethane (Methylchloroform). Specific brominated flame retardants such as the PBBOs and PBBs are not used in this product at all.

This product shall not contain the following materials banned in the RoHS Directive (2002/95/EC).

- Lead, Mercury, Cadmium, Hexavalent chromium, Polybrominated biphenyls (PBB), Polybrominated diphenyl ethers (PBDE).
- Content information about the six substances specified in “Management Methods for Control of Pollution Caused by Electronic Information Products Regulation” (Chinese: 电子信息产品污染控制管理办法)

Category	Toxic and Hazardous Substances					
	Lead (Pb)	mercury (Hg)	Cadmium (Cd)	Hexavalent chromium (Cr ⁶⁺)	Polybrominated biphenyls (PBB)	Polybrominated diphenyl ethers (PBDE)
OPIC Light Sensors	✓	✓	✓	✓	✓	✓

NOTE: ✓ indicates that the content of the toxic and hazardous substance in all the homogeneous materials of the part is below the concentration limit requirement as described in SJ/T 11363-2006 standard.

■ **Packing Specifications**

● **Taping Specification**

1. For the tape structure and dimensions, see Figure 2. The carrier tape structure incorporates a cover tape thermally bonded to it to protect the parts against electrostatic damage.
2. For the Reel structure and dimensional information, see Figure 3.
3. Product Insert Direction: The part orientation in the carrier tape is with the diode emitter toward the hole side of the tape, see Figure 4.

Fig. 2 Tape Structure and Dimension

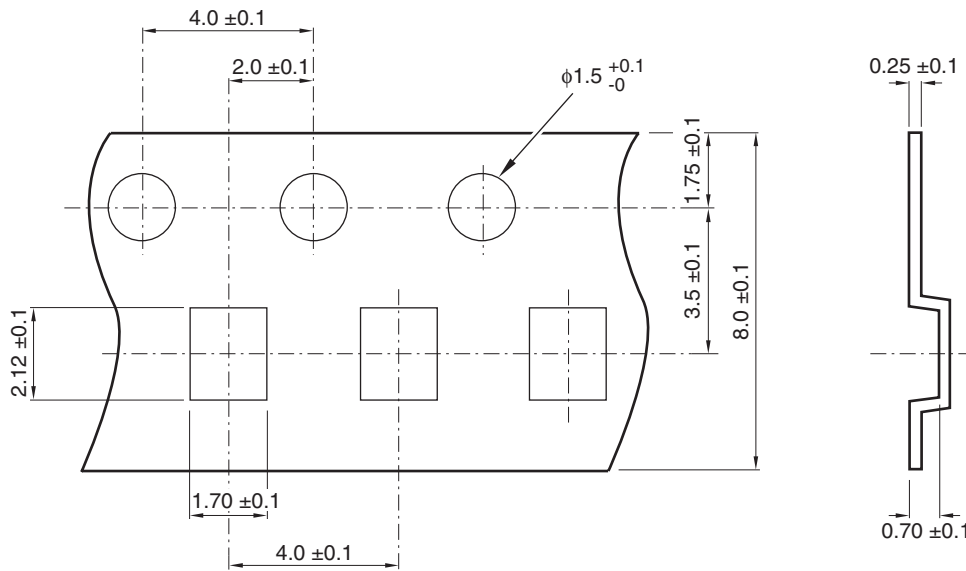

Fig. 3 Reel Structure and Dimension

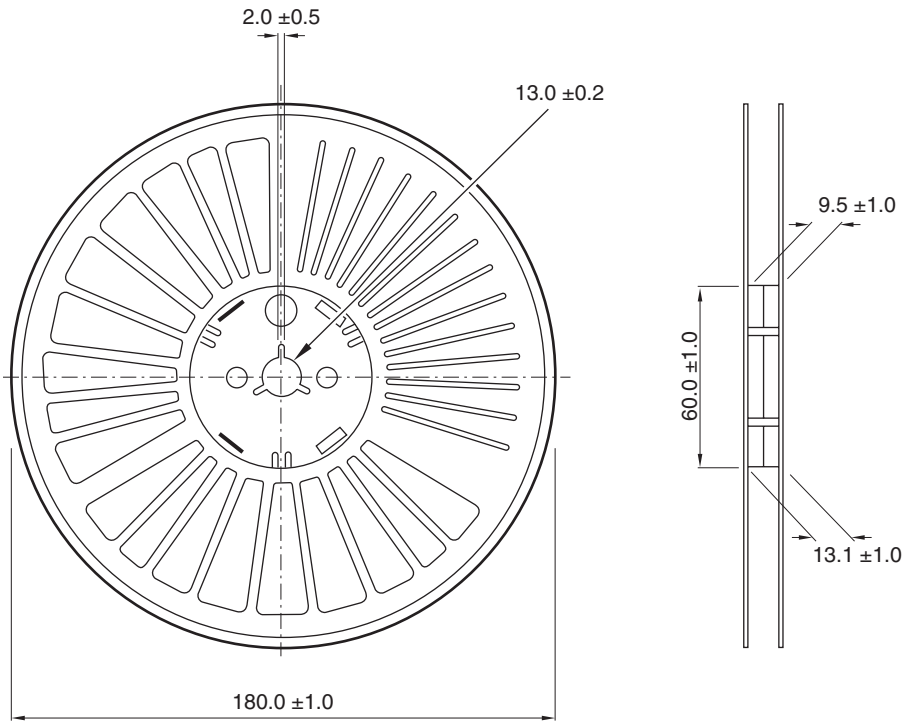
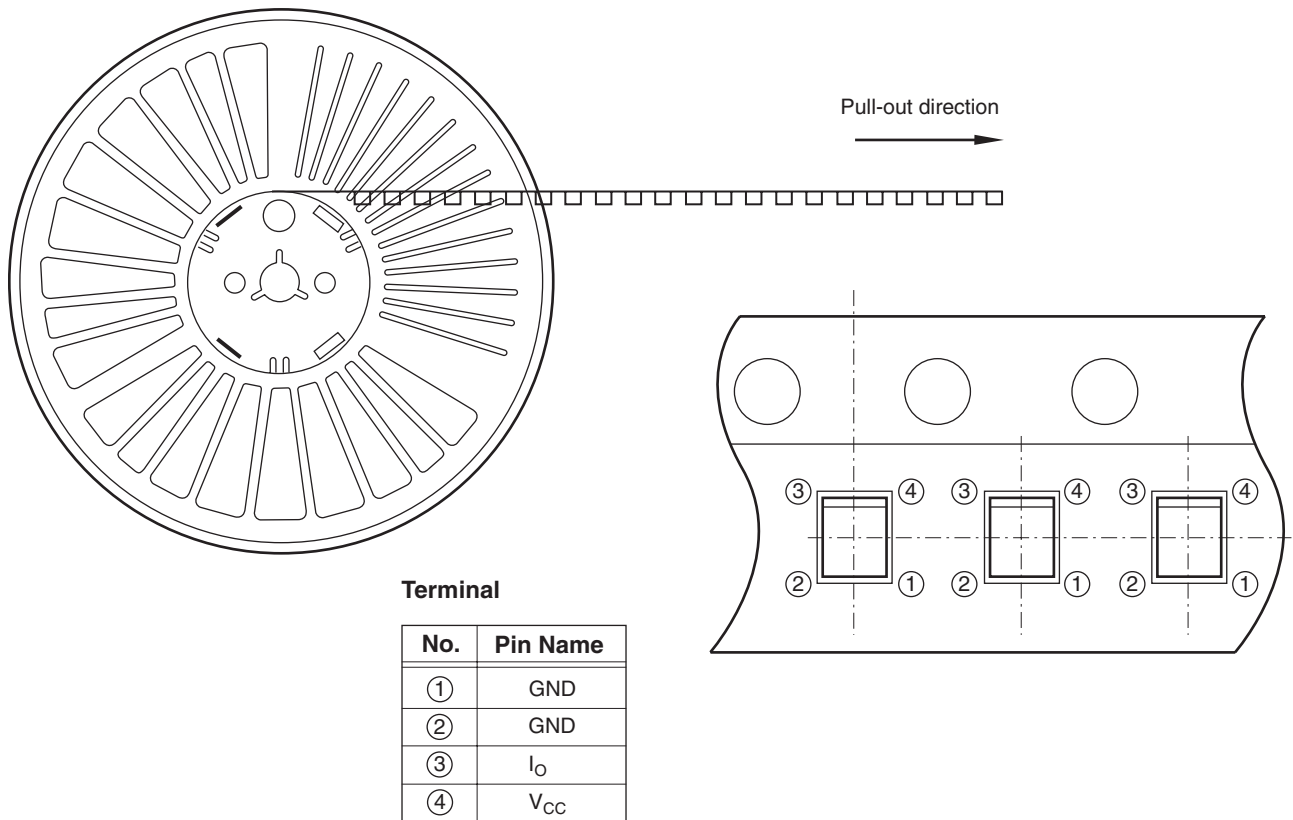

Fig. 4 Product Insertion Direction



■ Packing Materials

Name	Material	Quantity	Purpose
Aluminum laminated bag	Aluminum polyethylene	Refer to Packaging Method	Moisture proof
Label	Paper (made)	–	Indication of Model No. and Quantity
Humidity indicator card	Paper (made)	1 sheet/reel	Indication of Humidity

● Packaging Method

1. The ruled tape-reel and humidity indicator card are sealed inside the aluminum laminated bag.
2. The label is filled out and pasted on the bag.
3. The moisture-proof laminated bag is placed in the ruled case.

Package Shape	Product	Quantity	Moisture-proof Sack Quantity
Tape = reel (φ 180 mm)	1 ch type	2000 pcs./reel	1 reel/bag

Fig. 5 Inner Packing

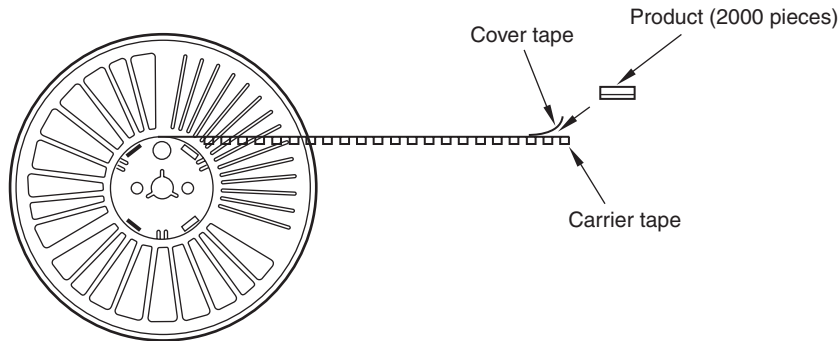

NOTES:

1. Inner packing material: Reel (PPE), Carrier tape (PC), Cover tape (PET)
2. Quantity: 2000 pieces/reel

Fig. 6 Packing Specification

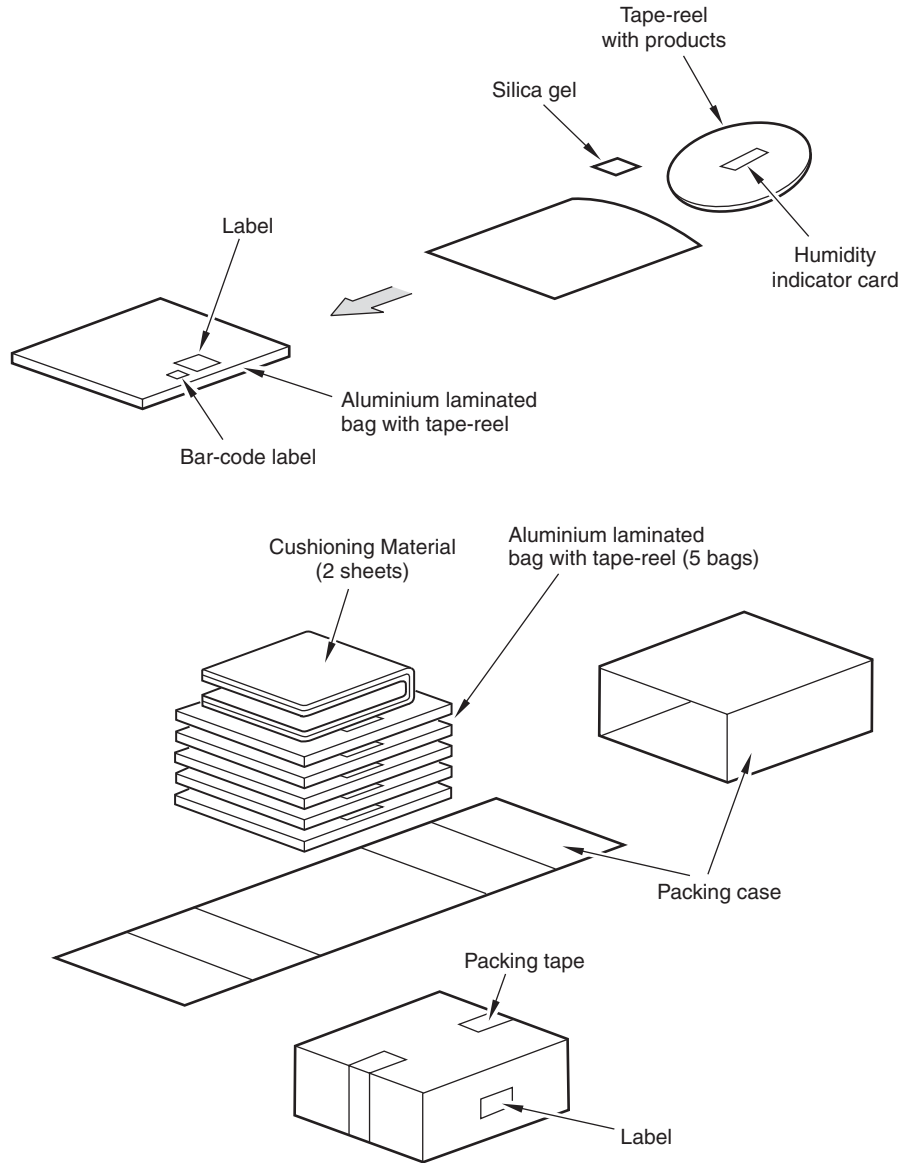

NOTES:

1. Outer packing material: Packing case (Corrugated cardboard), Cushioning Material (Urethane)
Aluminium laminated bag (Alumi-Polyethylene), Humidity indicator card (paper),
Label (paper), Silica gel, Packing tape
2. Quantity: 10000 pieces/box
3. Indication: Model number, quantity, and inspection date
4. Regular packaged mass: Approximately 600 g

■ Important Notices

· The circuit application examples in this publication are provided to explain representative applications of SHARP devices and are not intended to guarantee any circuit design or license any intellectual property rights. SHARP takes no responsibility for any problems related to any intellectual property right of a third party resulting from the use of SHARP's devices.

· Contact SHARP in order to obtain the latest device specification sheets before using any SHARP device. SHARP reserves the right to make changes in the specifications, characteristics, data materials, structure, and other contents described herein at any time without notice in order to improve design or reliability. Manufacturing locations are also subject to change without notice.

· Observe the following points when using any devices in this publication. SHARP takes no responsibility for damage caused by improper use of the devices which does not meet the conditions and absolute maximum ratings to be used specified in the relevant specification sheet nor meet the following conditions:

(i) The devices in this publication are designed for use in general electronic equipment designs such as:

- Personal computers
- Office automation equipment
- Telecommunication equipment (terminal)
- Test and measurement equipment
- Industrial control
- Audio visual equipment
- Consumer electronics

(ii) Measures such as fail-safe function and redundant design should be taken to ensure reliability and safety when SHARP devices are used for or in connection with equipment that requires higher reliability such as:

- Transportation control and safety equipment (i.e., aircraft, trains, automobiles, etc.)
- Traffic signals
- Gas leakage sensor breakers
- Alarm equipment
- Various safety devices, etc.

(iii) SHARP devices shall not be used for or in connection with equipment that requires an extremely high level of reliability and safety such as:

- Space applications
- Telecommunication equipment (trunk lines)
- Nuclear power control equipment
- Medical and other life support equipment (e.g. scuba)

· If the SHARP devices listed in this publication fall within the scope of strategic products described in the Foreign Exchange and Foreign Trade Law of Japan, it is necessary to obtain approval to export such SHARP devices.

· This publication is the proprietary product of SHARP and is copyrighted, with all rights reserved. Under the copyright laws, no part of this publication may be reproduced or transmitted in any form or by any means, electronic or mechanical, for any purpose, in whole or in part, without the express written permission of SHARP. Express written permission is also required before any use of this publication may be made by a third party.

· Contact and consult with a SHARP representative if there are any questions about the contents of this publication.