

## Tank Treads Kit (#28106)

For the Boe-Bot, Shield-Bot, and ActivityBot robot kits

Treads help your robot access varied terrain such as carpet, small rocks or imperfect surfaces. This kit involves removing your robot's wheels (and encoders\* if present), repositioning servos, and adding the treaded drive train.

\*The Tank Treads Kit is not compatible with Boe-Bot Encoders or ActivityBot Encoders; both of those rely on spoked wheels that are removed to mount the treads. See Kit Compatibility on page 4 for tips on using the Tank Treads with other Parallax Small Robot Kits and Accessories.

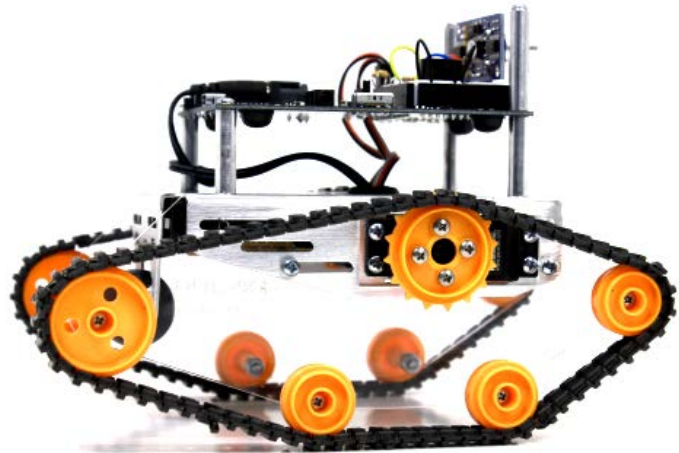

### Bill of Materials

Part #	Description	Qty
700-00002	4-40 Machine Screw, 3/8"	8
700-00003	4-40 Nut – 700-00003	24
700-00007	4-40 Machine Screw, 7/8"	8
700-00028	4-40 Machine Screw, 1/4"	8
700-00059	#4 Lock Washer	8
710-00008	1.5" Screw	2
713-00003	1.25" Standoff	2
721-32009	Acrylic Side Panels	2
713-00027	Spacer Disks	2
721-28106	Plastic Wheel and Rubber Tread set	1
725-00013	Servo Horns – may be standard X-type or round disk	2

### Tools Needed

You will need a #2 Philips screwdriver, wrench, and a 3/32" drill (or hobby knife like an X-acto® knife).

### Assembly

**Step 1:** From the set of wheels, cut out the following and trim off any burrs:

- (2) large wheels (with teeth)
- (2) large wheels (no teeth)
- (6) medium-sized wheels (no teeth)

The remaining wheels are not used for this application. However, the wheels with sprockets can be modified and used for customization if desired.

**Step 2:** The servo horn will need four of the holes enlarged for the 4-40 screws. The holes need to be smaller than the screw so that when the screws are inserted they will make their own threads. You can drill the holes using a 3/32" drill bit, or use an X-acto knife to enlarge the holes as shown below, depending on which servo horns were included in your kit. If you are using the knife, be sure not to over-enlarge the holes. By reaming with the knife a little from both the top and bottom, the hole will be more uniform in size.

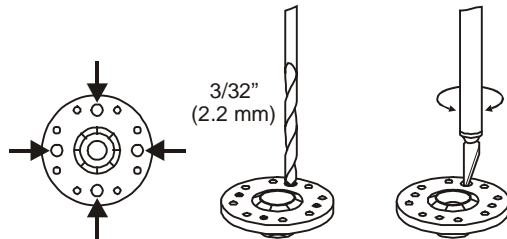

**Enlarge the Middle Holes  
if using Disc Servo Horns**

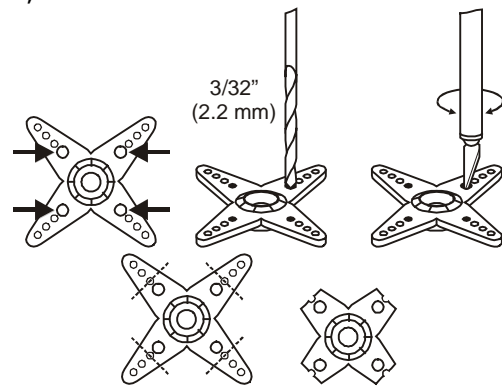

**Enlarge Inner Holes  
if using Standard Servo Horns**

**Step 3:** Thread four 1/4" length screws through a large toothed wheel from the convex side as shown, and then through a spacer disk. Gently self-tap the screws into the enlarged holes in the servo horn. Repeat for the other large wheel, spacer disk, and servo horn.

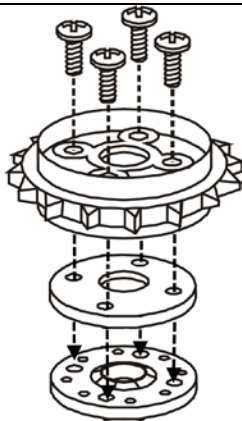

**Step 4:** Attach the 7/8" length screws and nuts to the remaining wheels (2 large and 6 medium in size) as shown below, and set aside.

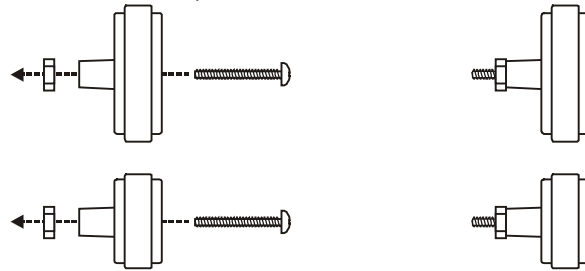

**Step 5:** Remove the wheels from your robot, and save the servo screw for the next step. Also remove encoder sensors if present. The servos should be mounted with the head toward the rear ball wheel as in Figure 5. The servo mounting tabs need to be on the outside of the robot chassis. If your servos are mounted the opposite way, or are mounted from inside the chassis, remove them and remount as shown.

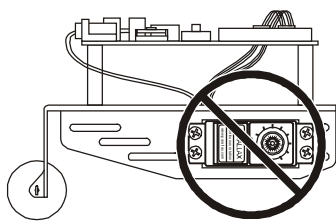

← **Wrong Way** →

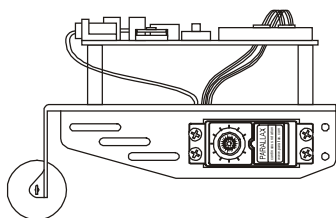

**Servo head is mounted  
toward tail wheel**

← **Right Way** →

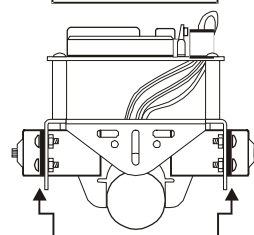
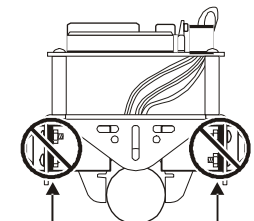

**Servo mounting tabs are  
outside of chassis**

**Step 6:** Remove the protective paper cover from the side panels, if desired.

Attach the side panels to the chassis, using 3/8" length screws and nuts as shown. Then attach the servo horn (with wheel) using the screw that came with the servo.

**IMPORTANT:** If your robot has a 5-cell battery pack, do not install the screw that goes into the top rear slot in the chassis. If you are using the Li-Ion Pack-Charger, see that section of Kit Compatibility on page 4.

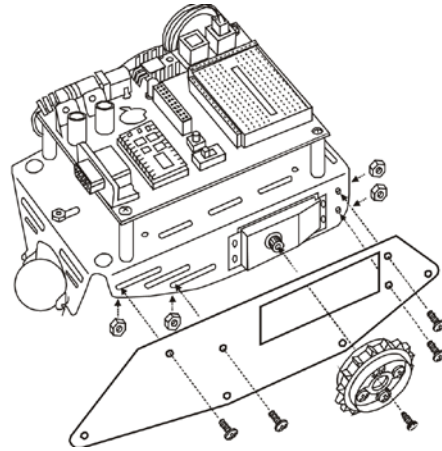

**Step 7:** Attach the remaining wheels by first tightening the nut on the wheel then loosening it 1/4 to 1/3 of a turn. Attach the wheel assembly to the frame with a nut and a lock washer on the inside of the frame. When the two nuts on each wheel are tightened, check to see that there is a very small gap between the wheel and outside nut to allow for easy rolling, as shown.

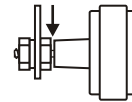

**Step 8:** Mount the remaining wheel assemblies with lock washers and nuts. When tightening, leave a very small gap on the wheel side so the wheel can turn freely, as shown.

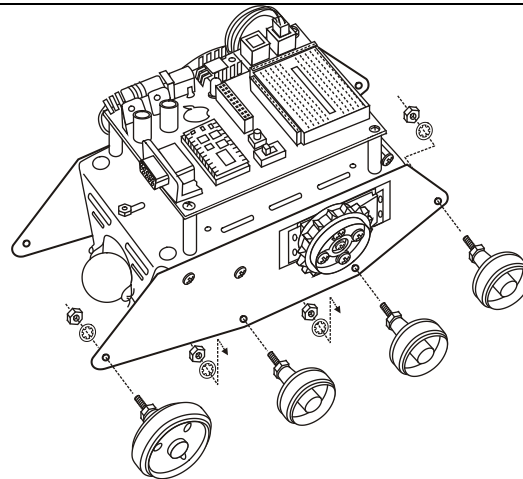

**Step 9:** Separate all the rubber tread pieces and connect together as shown below. Each loop contains 1 long, 2 medium and 2 short treads. Please do not pull the treads to disconnect from one another; please use scissors or an X-acto® knife. Pulling on the treads will stretch them beyond use. Check each wheel to make sure it rolls without binding. If any wheels bind, loosen the nut and remount to maintain a very small gap between the wheel and nut. Carefully stretch the tread over the wheels.

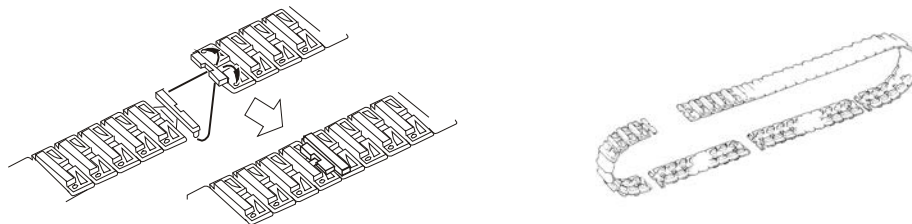

**Step 10:** The robot's breadboard circuit can be protected by installing the (2) 1.5" screws and (2) 1.25" spacers on the front standoffs.

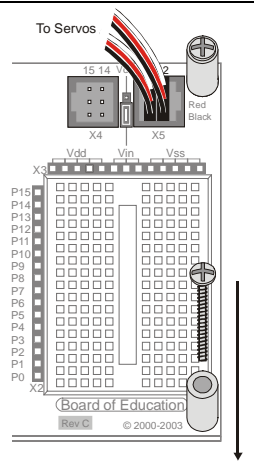

## Troubleshooting the Tread

If the tread is loose and comes off, check to see that all the wheels can roll easily but their screws are tightly attached to the side panels. If a wheel's screw feels floppy, loosen and then re-tighten the two nuts so that they are both firm against the acrylic. If the treads are still loose, move the rear wheel all the way to the outer end of its slot.

## Kit Compatibility & Programming Tips

The Tank Tread Kit is compatible with the Boe-Bot (28132 & 28832), ActivityBot (32500), and Shield-Bot (for Arduino, 130-35000). Please read the Encoders and 5-cell Battery Pack sections below.

**Encoders** — As noted on page 1, the Tank Tread Kit is **not** compatible with the Boe-Bot Encoder Kit (#28107), or with the stock ActivityBot encoders (#32501). Those encoders rely on spoked wheels that must be removed to mount the Tank Tread gear. Therefore, sensor-based autonomous roaming where precise straight-line travel is unimportant will be more successful than lists of maneuver sequences or dead reckoning. Remote control applications are also appropriate, where a gradual arc in straight-line travel can be corrected by the robot operator.

**5-cell Battery Packs** — the Propeller ActivityBot (#32500) and also the Shield-Bot (for Arduino, #130-35000) include 5-cell battery packs. To use the Tank Tread Kit with these robots, omit the mounting screw that would go in the chassis' top rear slot when mounting the side panels. This may cause slightly more flex in the panels.

**Boe-Bot Li-Ion Pack-Charger (#28988)** — The Tank Tread Kit may be used with care. Un-mount the Pack-Charger board first. When moving the servos to outside-mount position, be sure to re-mount with the nuts on the outside. When mounting each side panel, only use the upper rear slot in the chassis, and install

with the nut on the outside. Omit the screw that would go into the chassis' lower rear slot. Re-install the Pack-Charger last. Note that the extra weight of the Li-Ion batteries may cause the robot to stand on its back treads at times; this can be solved by adding a counterweight on top of the chassis just under the breadboard area.

**Crawler Legs Kit (#30055)** — These cannot be used at the same time as the Tank Treads, since both kits attach to the robot's servos.

**Line Follower Kits (#28108 & #28034)** — These are compatible not compatible as-is, since the Tank Treads side panels raise the chassis (and therefore the line follower sensors) higher off the surface than required for optimal performance.

**PING))) Mounting Bracket Kit (570-28015)** — This kit is compatible (and quite fun) with the Tank Tread Kit. Note that the extra weight may cause the robot to stand on its front treads at times; this can be fixed by adding a small counterweight on top of the chassis above the tail wheel area.

**Speed and Maneuvers** — Your robot's normal servo control code can be used with the Tank Tread Kit. However, the treads cause a lower ground speed than wheels. Therefore, the code routines to execute maneuvers need to last longer to go the same distance or to turn to the same angle.

**Turning** — Care must be taken when making all but gradual arcs for turns. To turn sharp right or left, rotate the servos in opposite directions so the robot pivots around its center. This will help the treads stay in place. If your program keeps one motor still while rotating the other one to make a turn, the sideways pressure on the staying-still tread may cause the tread to slip off of its wheels, especially on rough, soft surfaces.

**ActivityBot abdrive.h library** — To "turn off" the abdrive library's expectation encoder feedback with a calibrated ActivityBot, use `drive_feedback(0)`; at the beginning of the main routine. Then, your program may still use the functions `drive_speed`, `drive_ramp`, and `drive_rampStep`. Do not use `drive_goto`. Ramping into and out of high-speed maneuvers is recommended.

**Examples** — Check for application examples and code from [www.parallax.com](http://www.parallax.com); search "28106."

**Revision History** — 3.0. Supports acrylic side panels and additional spacer replacing metal side panels; added kit compatibility info for ActivityBot, Shield-Bot, and various accessories. 3.1: Corrected drawing of spacer in Step 3.