

Propeller Robot Controller

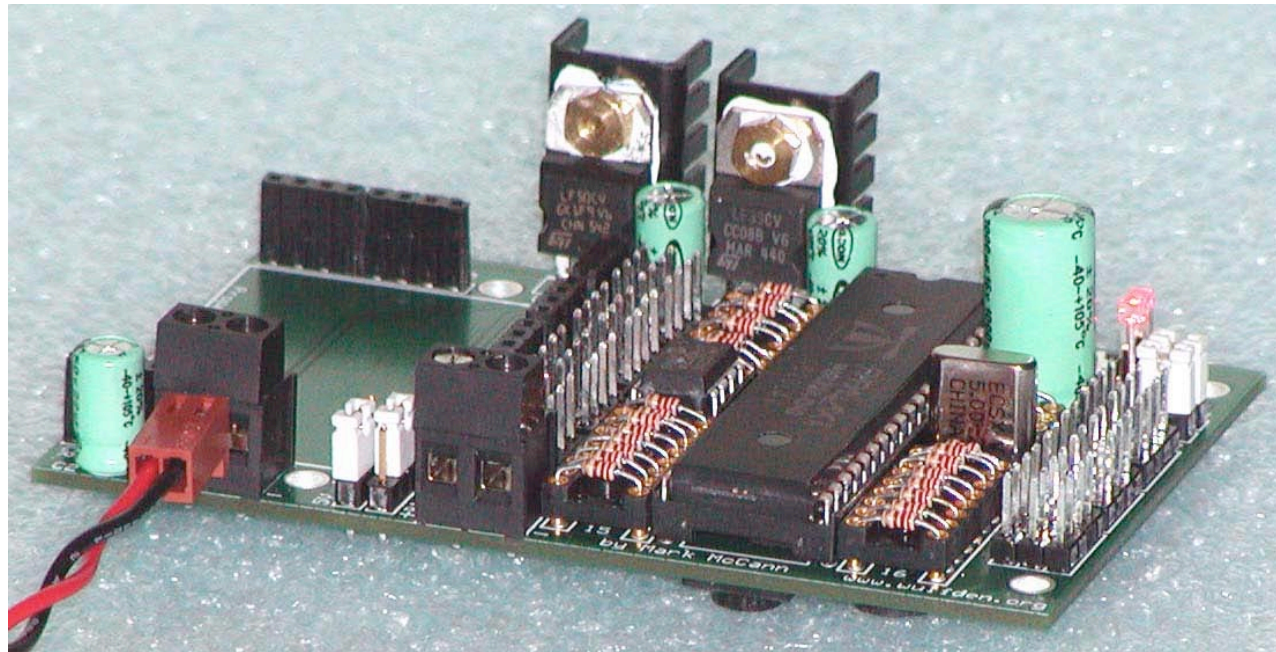

Board Configuration Information

A visual guide by
Russ Ferguson 8/11/2006
edited by Brian Riley

PRC Serial Connection

□ USB2SER

- Pins for connector (from left to right) are:
Vss, Rx, Tx, RES.

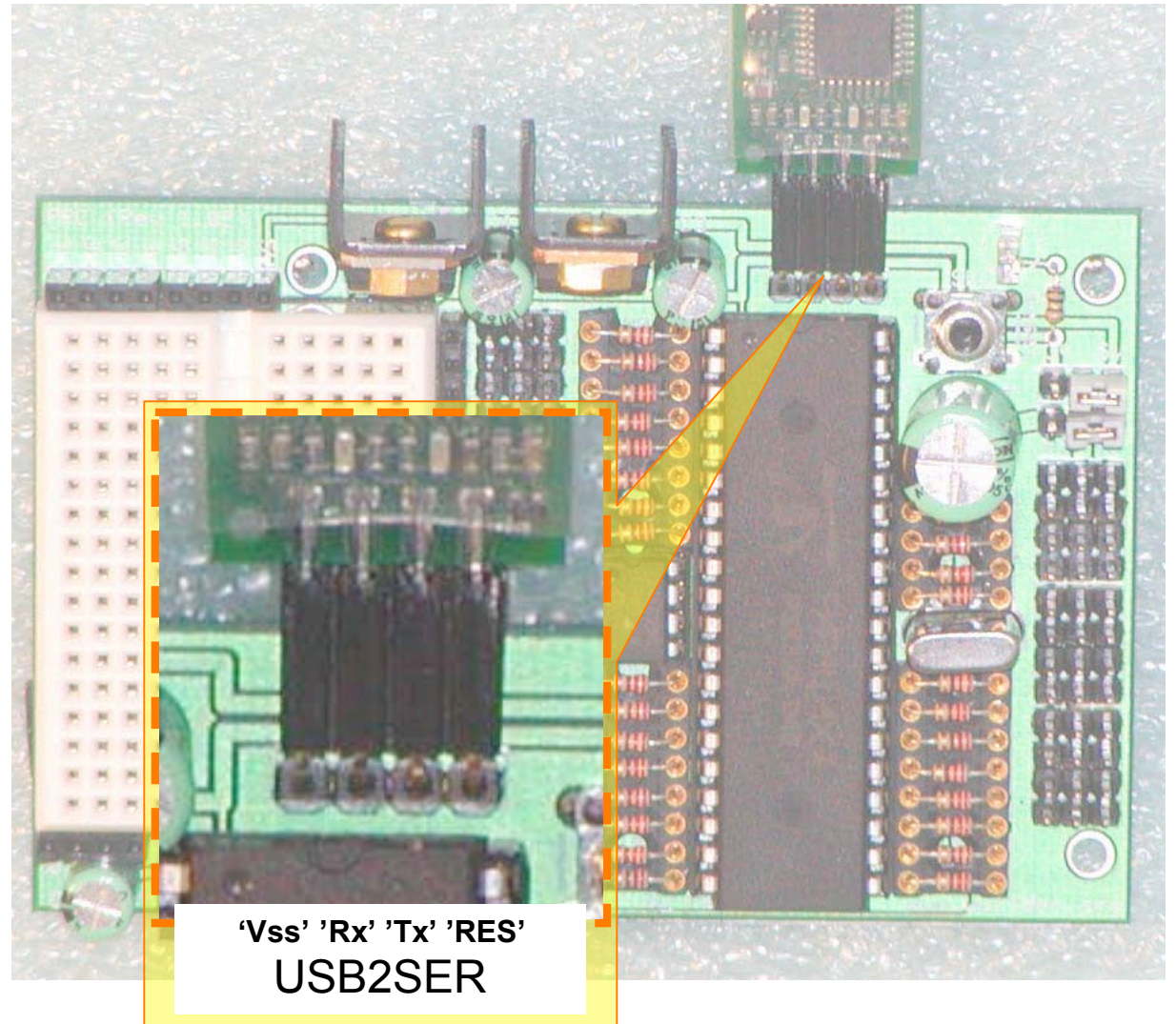

PRC Battery Connections

□ Batt1

- Does not provide power for the PRC board or the Propeller chip.
- The PRC does not provide a voltage regulator for this source.
- The jumpers for J1 and J3 can be placed on the 'B1' side so that 'Batt1' is used as the power source for devices attached to the PRC board.

□ Batt2

- Provides power for the PRC board, including the Propeller chip itself.

When only one battery is used it must be connected to 'Batt2'.

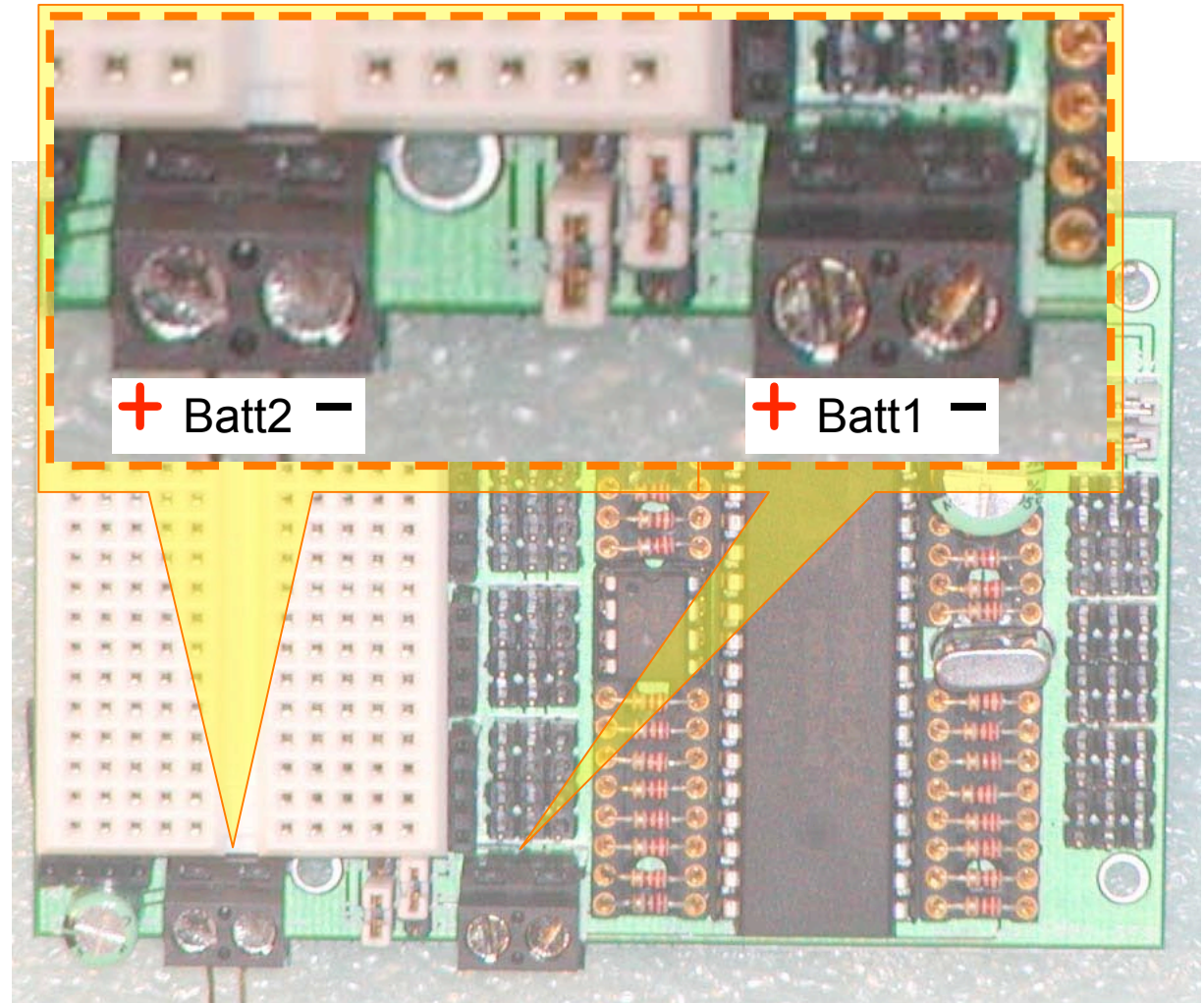

PRC Power Jumpers

□ JP1, JP3

- JP1 - Power source option for **S0 – S15**.
- JP3 - Power source option for **S16 – S27**.
- Jumper placed on 'VR' side selects the regulated '5v' or '3.3v' as jumpered by JP2.
- Jumper placed on 'B1' side selects the power provided by 'Batt1'.

□ JP2, JP4

- Jumper on '5v' will connect the 5v regulator to 'VR' on JP1 and JP3.
- Jumper on '3v' will connect the 3.3v regulator to 'VR' on JP1 and JP3.

When the jumper on JP1 or JP3 is on the 'B1' side then a battery must be connected to 'Batt1'. It can be the same battery that is connected to 'Batt2'.

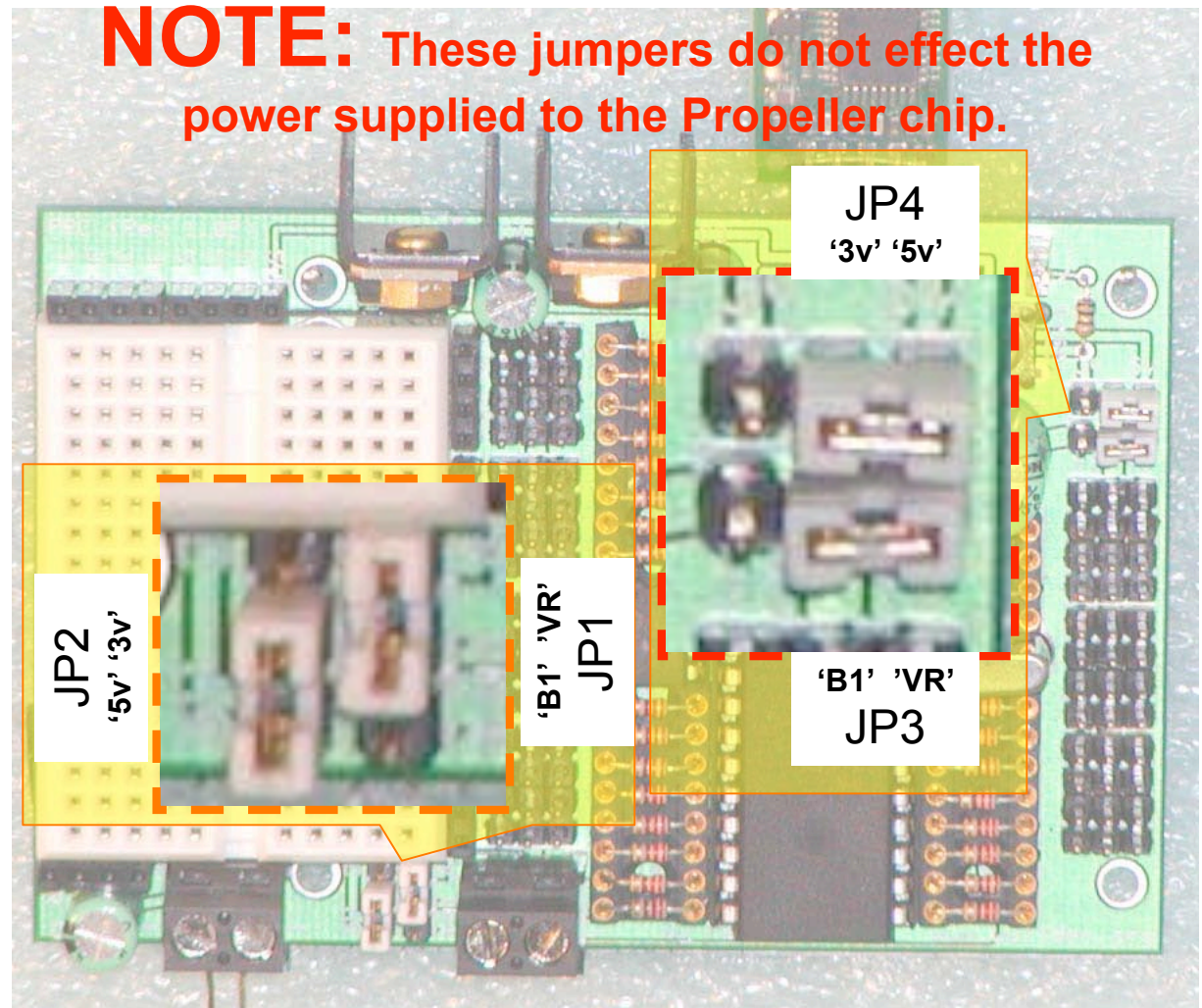

PRC Servo Connections

□ S0 – S15

- Pins for connectors (from left to right) are:
Vss,
+ (selected by JP1 & JP2),
Signal (as selected).

□ S16 – S27

- Pins for connectors (from left to right) are:
Signal (as selected),
+ (selected by JP3 & JP4),
Vss.

Pins on S0 to S15 are configured opposite the pins on S16 to S27.

The Propeller I/O pins are not directly connected to any of the Servo connections, or to the bread board sockets. Propeller Pin jumpers must be in place before the Servo connections will work.

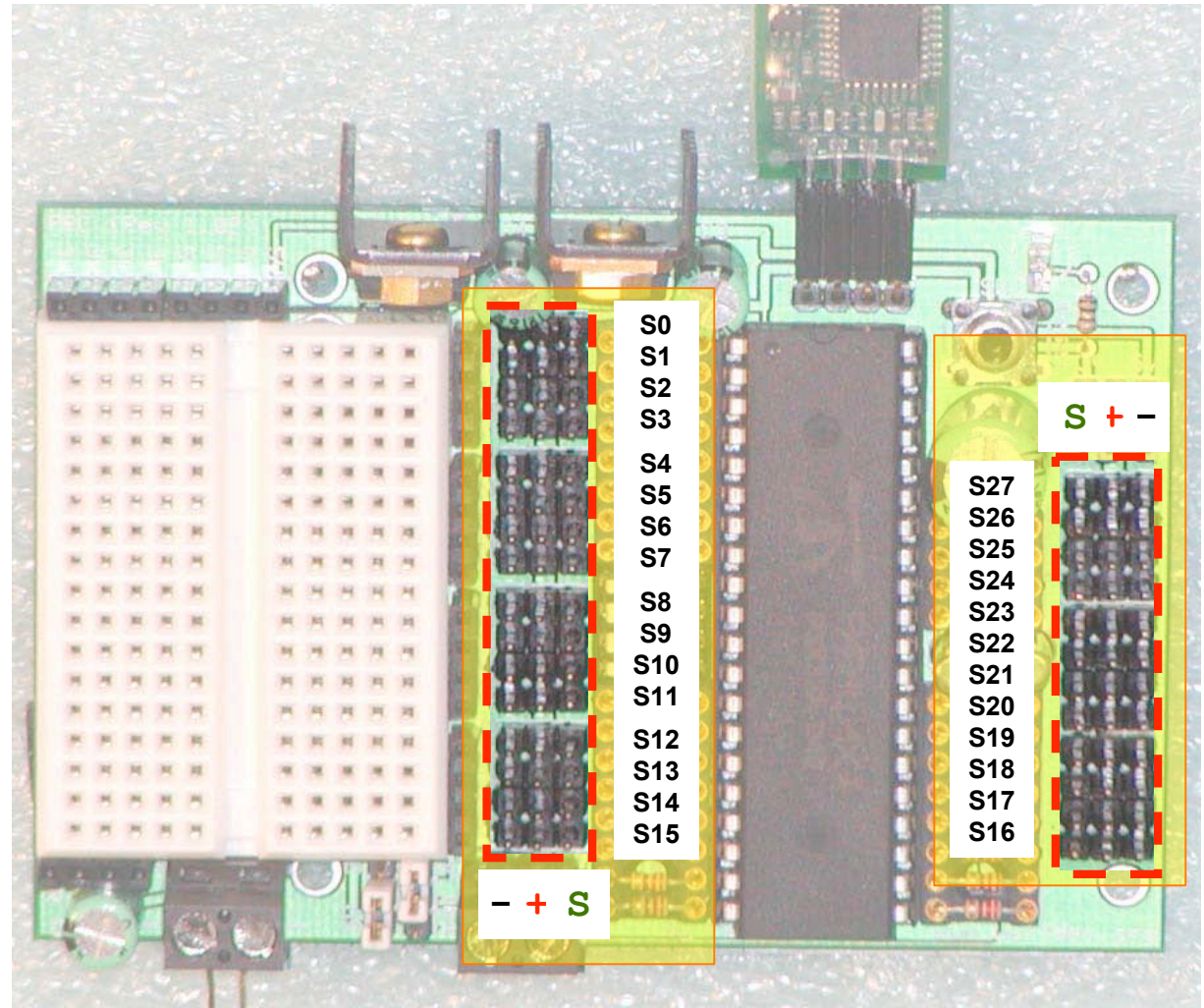

PRC Propeller Pin Jumpers

□ P0 – P27

• Propeller I/O pins.

□ S0 – S15

• Servo Connector Signal pins and Bread Board Signal pins

□ S16 – S27

• Servo Connector Signal pin.

Other configurations might include component carriers or risers to allow installation of other types of connectors.

Jumpers must be installed to enable the I/O connectors on the PRC.

(220 ohm current limiting resistors were installed as jumpers in the picture. When connecting to 5v devices, the recommended value is 4.7K as supplied with the kit.)

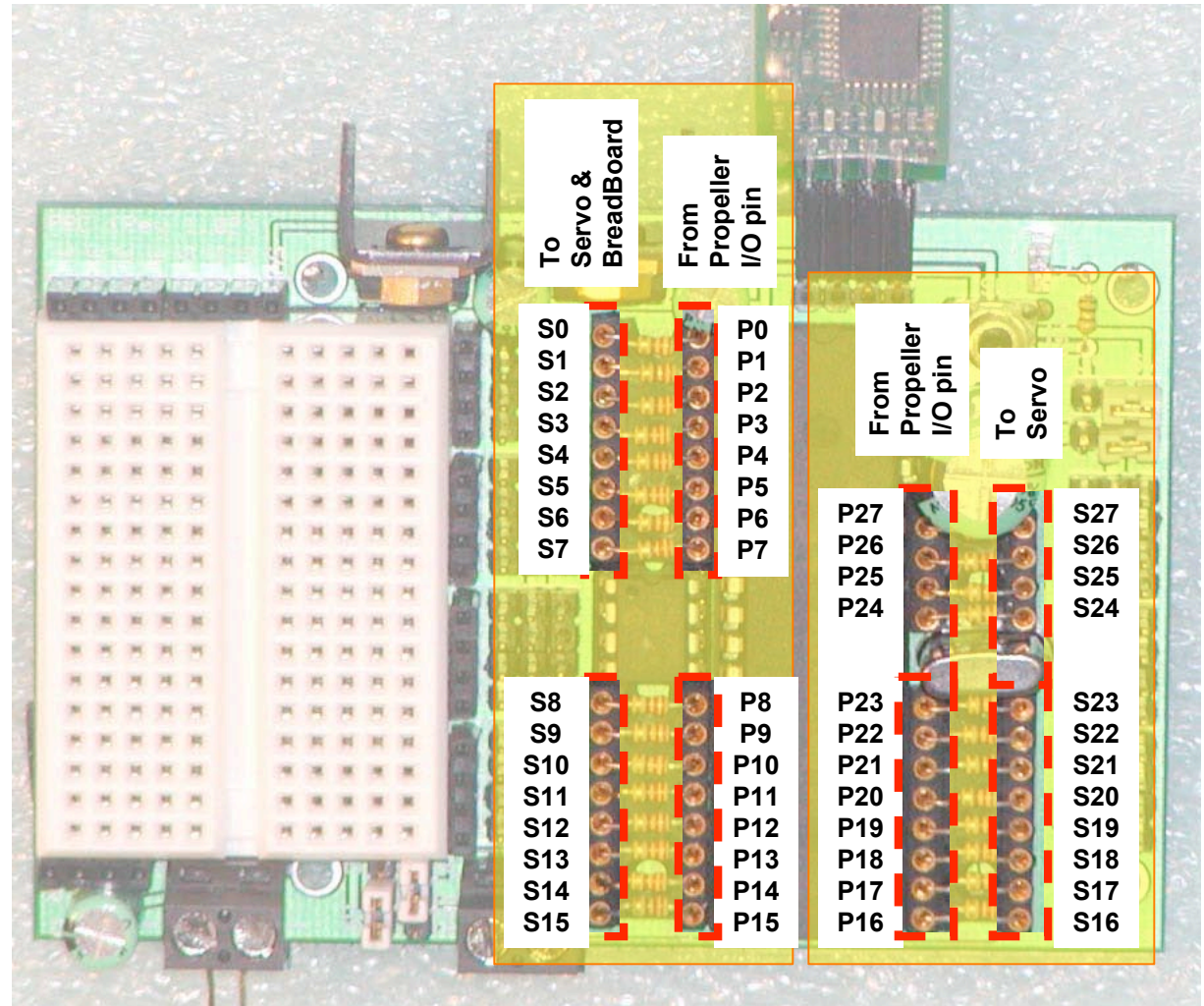

PRC Bread Board Connections

□ B0 – B15

- Signal (as selected by Propeller Pin Jumpers).

The Propeller I/O pins are not directly connected to any of the Servo connections, or to the bread board sockets. Propeller pin jumpers or current limiting resistors must be in place. The recommended value when interfacing to 3V devices is 220 ohms and to 5v devices is 4.7K ohms must be in place before the Servo connections will work.

